

Simple Circuits

Objective

You will create several simple circuits and use a digital multimeter and an ammeter to discover how the current and the potential differences are distributed in the various types of circuits.

Materials

- | | |
|---|---------------------------------|
| 1. Alligator clips | 30V) |
| 2. Alligator-to-alligator wires (large) | 5. Fluke digital multimeter |
| 3. Banana-to-banana wires | 6. Pasco 5-amp ammeter |
| 4. Fisher 1V/30V power supply (set to | 7. Simple circuit circuit board |

Introduction

The difference in electric potential across an electric circuit element is known as the “potential difference”, and is sometimes referred to as “the voltage drop (or increase) across” the element, since electric potential is measured in volts (V, but don’t confuse volts V with potential V). The symbol for potential difference is ΔV . An electric potential difference will cause an electric current I to flow in a closed circuit. A battery is a common source of electric potential difference. In this lab you will use a DC power supply as your source of electric potential difference. You may assume that all of the resistors R that you use are ohmic, that is the amount voltage across the resistor is directly proportional to the amount of current running through it.

Procedure

Part 1: One Instance of a Simple Circuits

Before turning on your power supply ensure that both voltage control knobs are set to their lowest position (all the way counter-clockwise) and that the current control knob is set to its highest position (all the way clockwise). This will provide you with proper control of the

voltage of the power supply. Next look at the back of the power supply, and verify that the voltage control switch is on the 30 V setting. Turn on the power supply, and use the coarse and fine voltage controls along with the digital multimeter to set the power supply potential difference to 20.0 V. This is the voltage that you will use for the entire lab.

Once this is accomplished use the circuit elements you find on your lab table to set up the simple circuit shown in Figure 1. Use the 0.5 A range on the ammeter. Read from the ammeter the electric current flowing into the resistor.

At this point you should use your digital multimeter to verify that the power supply voltage is still 20.0 V. Next compare the current flowing into the resistor with the current flowing out of the resistor. To do this, change the location of the ammeter to the current outlet side of the resistor. Compare this current reading to the reading you got on the inlet side of the resistor. What do you conclude?

Now use the digital multimeter to measure the electric potential difference across the 100- Ω resistor. Use this potential difference and Ohms Law to calculate a current through the resistor. How does this calculated current compare with the values you read on the ammeter?

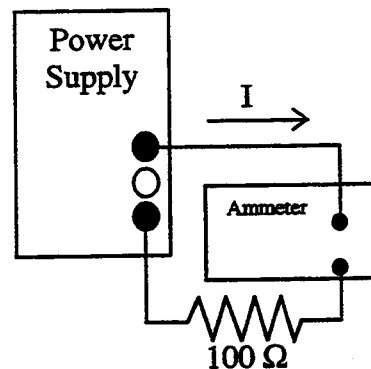

Figure 1: *One instance of a simple circuit*

Part 2: A Series Circuit

Assemble the series circuit shown in Figure 2. Verify your power supply voltage is still at 20.0 V. Prior to measuring them, predict the current in the circuit and the potential difference across each resistor. Compare the measured values with what you predicted. Explain any differences in your lab report.

Now predict what will happen if one of the 100- Ω resistors is replaced by a 200- Ω resistor while the power supply maintains a 20.0 V potential difference. Remove one 100- Ω resistor from the circuit, and replace it with the 200- Ω resistor. Once again compare your predictions with the measurements that you take. Repeat the whole procedure for the 300 Ω -resistor.

Based upon the data that you took, explain in your own words why the potential differences across the two resistors changed the way that they did. Think about what must remain constant and what quantities must be equal for two resistors in series. Remember that the resistors are ohmic.

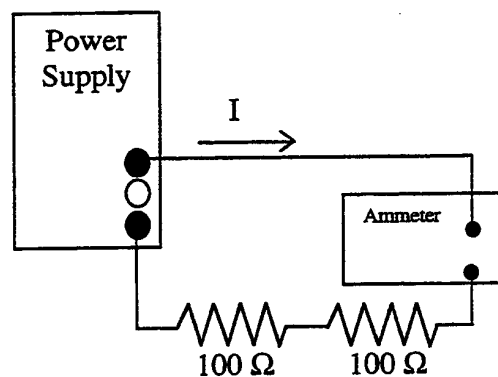

Figure 2: *Series Circuit*

Part 3: A Parallel Circuit

Assemble the circuit shown in Figure 3. Insert the ammeter in the circuit before the point marked “A” in Figure 3. Check that your power supply potential difference is still at 20.0 V. Record the current in this location in the circuit.

At the point marked “A”, the electric current in the circuit splits, much like the current in a river would under similar circumstances. You need to measure the current flowing in both branches of the circuit, downstream of the split. This will require you to remove the ammeter from its initial location and insert it first in one downstream branch and then in the other. Record the current in each branch, then compare their sum with the first current reading you took. What can you conclude?

Consider the resistances in the two branches of the circuit, and their respective currents. What relationship between current and resistance does this suggest? Measure the potential difference across each of the resistors, how do they compare? Now predict what will happen to the current in each branch if the 200- Ω resistor is replaced with a 100- Ω resistor, record your prediction.

Replace the 200- Ω resistor with the second 100- Ω resistor. Once again measure the current in each branch by inserting the ammeter. Were your predictions correct? Did the current in the original 100- Ω resistor change? Did the total current in the circuit change? Was your idea about the relationship between resistance and current in each branch correct?

Measure the potential difference across each resistor. How does the potential difference across the resistors compare with the potential difference across the resistors when the 200- Ω resistor was in the circuit? What can you conclude?

What will happen to the currents through the two branches if the 300- Ω resistor replaces one of the 100- Ω resistors? Record your predictions and then verify them by replacing one of the 100- Ω resistors with the 300- Ω resistor and measuring the current in each branch.

Based upon the data that you took, explain in your own words why the current through the two branches changed the way that they did. Think about what must remain constant and what quantities must be equal for the two resistors. Remember that the resistors are ohmic.

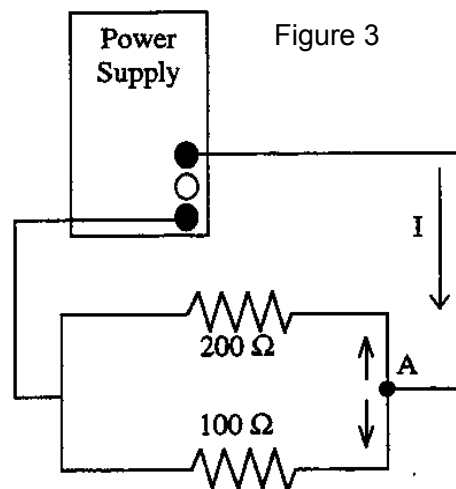

Figure 3: *Parallel Circuit*

Part 4: A More Complex Circuit

When you reach this point let your lab instructor know. He or she will provide you with a circuit diagram of a more complex circuit. You should predict the current through and the potential difference across each of the resistors in the circuit. Then use the apparatus available to you and set up the circuit. Using your ammeter and your digital multimeter, verify that your predicted currents and potential differences are correct.

Upon completing this lab please disconnect all wires and circuit elements, unplug the power supply, and turn the digital multimeter off.